

FAN5029

8-Bit Programmable 2- to 5-Phase Synchronous Buck Controller

Features

- Selectable 2-, 3-, 4-, or 5-phase operation at up to 1MHz per phase
- $\pm 7.7\text{mV}$ worst-case differential sensing error
- Active current balancing between the output phases
- Power good and crowbar blanking supports on-the-fly VID code changes
- Selectable VR10 extended (7-bit) and VR11 (8-bit) VID tables
- Programmable short-circuit protection and latch-off delay
- Programmable soft start ramp

Applications

- Desktop PC/Server processor power supplies for existing and next generation Intel processors
- VRM modules products

Part Numbers

- FAN5029MPX is not for new designs.
- The FAN5029MPX_NAAC238 replaces the FAN5029MPX and is compatible with all VR10 and VR11 processors.

Description

The FAN5029 is a multi-phase buck switching regulator controller optimized to convert a 12V input supply to the processor core voltage required by high-performance Intel® processors. It has an internal 8-bit DAC that converts a digital voltage identification (VID) code that is sent from the processor to set the output voltage between 0.5V and 1.6V. It outputs a PWM to external MOSFET drivers that, in turn, drive the switching power MOSFETs. The switching frequency of the design is programmable by a single resistor value and the number of phases can be programmed to support 2-, 3-, 4-, or 5-phase applications.

The FAN5029 also includes programmable no-load offset and droop functions to adjust the output voltage as a function of the load current, as required by the Intel specifications. The FAN5029 also provides an accurate and reliable short-circuit protection function with an adjustable over-current set point.

The FAN5029 is specified over the extended commercial temperature range of 0°C to +85°C and is available in a 40-lead MLP package.

Ordering Information

Part Number	Temperature Range	Package Type	Lead Free	Packing Method	Quantity per Reel
FAN5029MPX	Not For New Designs				
FAN5029MPX_NAAC238	0°C to 85°C	MLP-40	Yes	Tape and Reel	3,000

For more information, please contact Ron Berthiaume at ronald.berthiaume@fairchildsemi.com.

Block Diagram

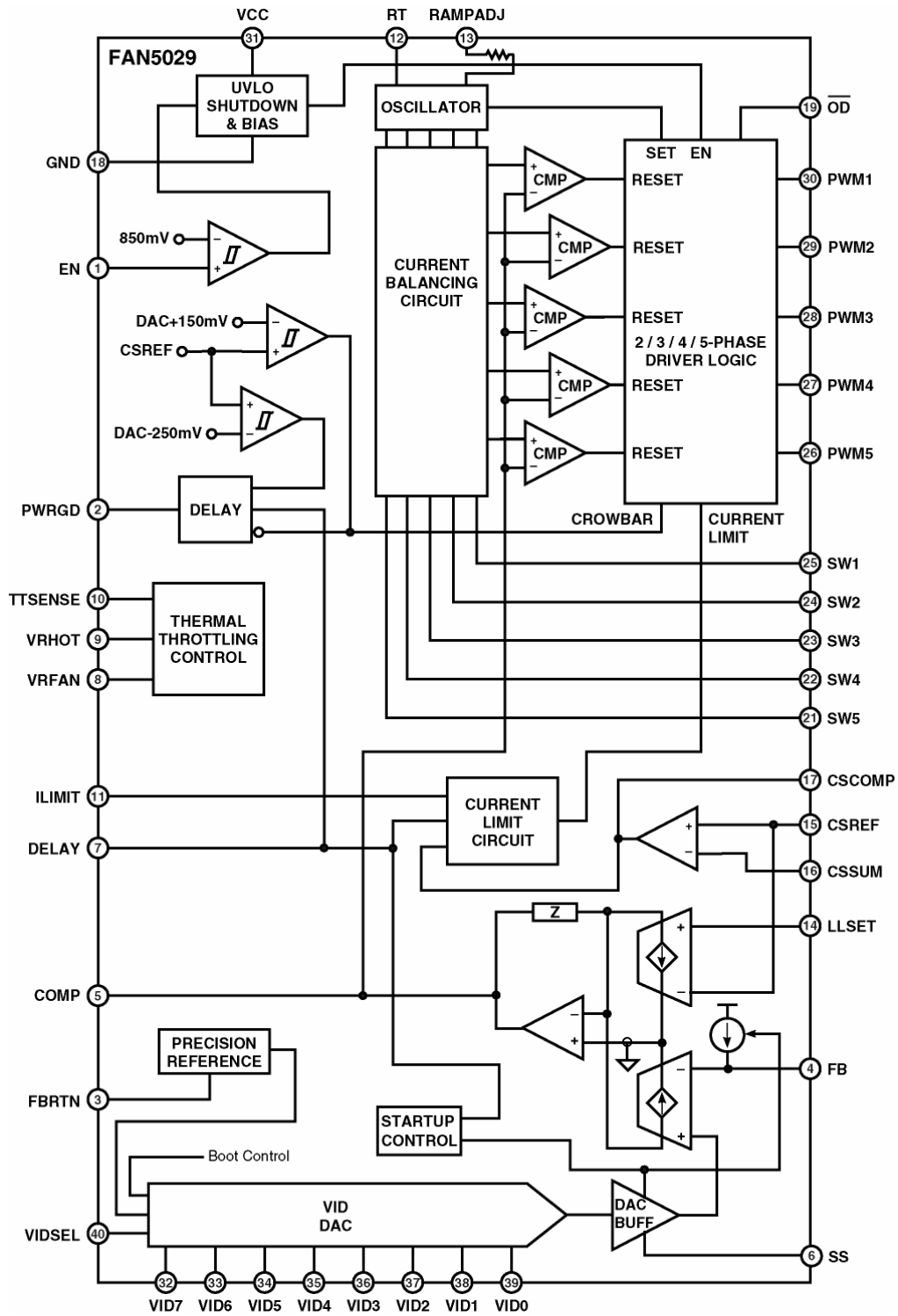

Figure 1: Block Diagram

TRADEMARKS

The following are registered and unregistered trademarks Fairchild Semiconductor owns or is authorized to use and is not intended to be an exhaustive list of all such trademarks.

ACEx™	GlobalOptoisolator™	OCXPro™	μSerDes™	TinyBoost™
ActiveArray™	GTO™	OPTOLOGIC®	SILENT SWITCHER®	TinyBuck™
Bottomless™	HiSeC™	OPTOPLANAR™	SMART START™	TinyLogic®
Build it Now™	i ² C™	PACMAN™	SPM™	TINYOPTO™
CoolFET™	<i>i-Lo</i> ™	POP™	Stealth™	TinyPower™
CROSSVOLT™	ImpliedDisconnect™	Power247™	SuperFET™	TinyPWM™
DOME™	IntelliMAX™	PowerEdge™	SuperSOT™-3	TruTranslation™
EcoSPARK™	ISOPLANAR™	PowerSaver™	SuperSOT™-6	UHC®
E ² CMOS™	LittleFET™	PowerTrench®	SuperSOT™-8	UniFET™
EnSigna™	MICROCOUPLER™	QFET®	SyncFET™	VCX™
FACT®	MicroFET™	QS™	TCM™	Wire™
FACT Quiet Series™	MicroPak™	QT Optoelectronics™		
FAST®	MICROWIRE™	Quiet Series™		
FASTr™	MSX™	RapidConfigure™	Across the board. Around the world.™	
FPS™	MSXPro™	RapidConnect™	Programmable Active Droop™	
FRFET™	OCX™	ScalarPump™	The Power Franchise®	

DISCLAIMER

FAIRCHILD SEMICONDUCTOR RESERVES THE RIGHT TO MAKE CHANGES WITHOUT FURTHER NOTICE TO ANY PRODUCTS HEREIN TO IMPROVE RELIABILITY, FUNCTION OR DESIGN. FAIRCHILD DOES NOT ASSUME ANY LIABILITY ARISING OUT OF THE APPLICATION OR USE OF ANY PRODUCT OR CIRCUIT DESCRIBED HEREIN; NEITHER DOES IT CONVEY ANY LICENSE UNDER ITS PATENT RIGHTS, NOR THE RIGHTS OF OTHERS. THESE SPECIFICATIONS DO NOT EXPAND THE TERMS OF FAIRCHILD'S WORLDWIDE TERMS AND CONDITIONS, SPECIFICALLY THE WARRANTY THEREIN, WHICH COVERS THESE PRODUCTS.

LIFE SUPPORT POLICY

FAIRCHILD'S PRODUCTS ARE NOT AUTHORIZED FOR USE AS CRITICAL COMPONENTS IN LIFE SUPPORT DEVICES OR SYSTEMS WITHOUT THE EXPRESS WRITTEN APPROVAL OF FAIRCHILD SEMICONDUCTOR CORPORATION.

As used herein:

- Life support devices or systems are devices or systems which, (a) are intended for surgical implant into the body or (b) support or sustain life, and (c) whose failure to perform when properly used in accordance with instructions for use provided in the labeling, can be reasonably expected to result in a significant injury of the user.
- A critical component in any component of a life support, device, or system whose failure to perform can be reasonably expected to cause the failure of the life support device or system, or to affect its safety or effectiveness.

PRODUCT STATUS DEFINITIONS

Definition of Terms

Datasheet Identification	Product Status	Definition
Advance Information	Formative or In Design	This datasheet contains the design specifications for product development. Specifications may change in any manner without notice.
Preliminary	First Production	This datasheet contains preliminary data; supplementary data will be published at a later date. Fairchild Semiconductor reserves the right to make changes at any time without notice to improve design.
No Identification Needed	Full Production	This datasheet contains final specifications. Fairchild Semiconductor reserves the right to make changes at any time without notice to improve design.
Obsolete	Not In Production	This datasheet contains specifications on a product that has been discontinued by Fairchild Semiconductor. The datasheet is printed for reference information only.

Rev. I22